

Wet Movers

Ideal cart to transport wet items such as produce, flowers, or any other products that may leak. Reversible pan design captures moisture and reduces slip and fall accidents while efficiently transporting products.

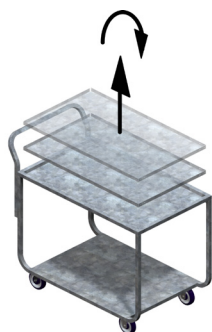

Both shelves are reversible on aluminum models



Top shelf is reversible on galvanized model



ALUMINUM UNIT FEATURES: (8040332)

- Constructed from all welded heavy duty sanitary aluminum
- Both shelves are removable and reversible for easy cleaning
- Cart comes with either (4) wheels or the heavy duty (6) wheel design

SHIPS FULLY ASSEMBLED FOR IMMEDIATE USE

GALVANIZED UNIT FEATURES: (8000072)

- Ships fully assembled for immediate use
- All welded heavy duty galvanized steel
- Top shelf is removable and reversible for easy cleaning.

OPTIONS:

- Full Perimeter Bumper (FPB) (inquire with your customer service representative for ordering)

REPLACEMENT PARTS:

- 8040332 and 8041059 4-Wheel Model: (2) front 5" x 1.25" rigid casters with polyurethane wheels, Order #B000325 and (2) rear 5" x 1.25" swivel casters with polyurethane wheels, Order #B000312. Fasteners Replacement Order #B000543 and #B001257.

- 8040333 and 8041060 6-Wheel Model: (2) center 5" x 1.25" rigid casters with polyurethane wheels, Order #B000325. (4) corner 5" x 1.25" swivel casters with polyurethane wheels, Order #B000312. Fasteners Replacement Order #B000543, #B001257, and #B000923.

- 80000072 4-Wheel Model: (2) front 5" x 1.25" rigid casters with polyurethane wheels, Order #B000325 and (2) rear 5" x 1.25" swivel casters with polyurethane wheels, Order #B000312. Fasteners Replacement Order #B000062 and #B001257.

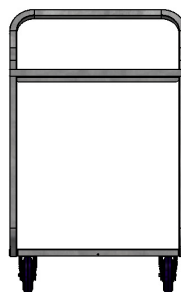
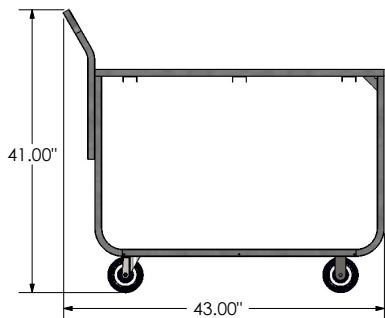
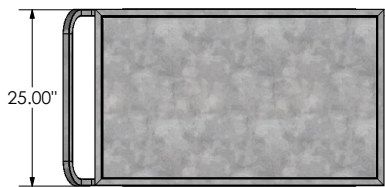

Freight Class: 300
NMFC Code: 164390-S2

8000072

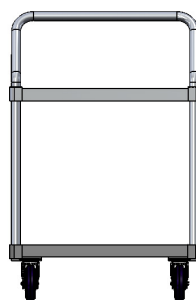
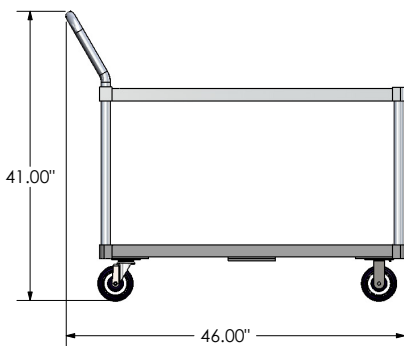
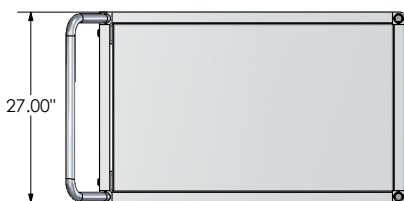

8040332

Order #	Model	W	L	H	# of Casters	Cart Capacity	Weight	Full Perimeter Bumpers
8040332	AL-WPM-2746-4 WET PRODUCE MOVER	27"	46"	41"	4	750 lbs.	54 lbs.	No
8041059	AL-WPM-2746-4 FPB WET PRODUCE MOVER	27"	46"	41"	4	750 lbs.	54 lbs.	Yes
8040333	AL-WPM-2746-6 WET PRODUCE MOVER	27"	46"	41"	6	1000 lbs.	58 lbs.	No
8041060	AL-WPM-2746-6 FPB WET PRODUCE MOVER	27"	46"	41"	6	1000 lbs.	58 lbs.	Yes
8000072	WPM-2542-4-G GALV WET PRODUCE MOVER	25"	43"	41"	4	750 lbs.	65 lbs.	No

Can't find exactly what you need? Give us a call and we'll help you with the perfect solution!

