

Dairy Distribution Cart

This distribution cart can be used in a variety of distribution, storage, stocking, and merchandising applications. The dairy industry has used this type of cart for years to transport from the dairy to the retailer, then reverse logistics back to the dairy.



Shown loaded

FEATURES:

- Ease of mobility reduces damage done to products on the cart and store fixtures
- Shelves are slanted to keep products from falling off cart, but still allows products to be pulled off easily
- Nestable design folds completely flat
- Durable zinc plated finish
- Heavy duty steel construction
- 1000 lb.. capacity
- Cart moves easily on hard surfaces with (4) 5" x 2" phenolic wheels with swivel casters. Replacement Order #B001009



1. Fold up shelves



2. Fold in sides individually

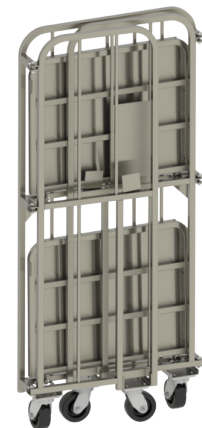

3. Secure folded cart when storing



Distribution

Freight Class: 175
 NMFC Code: 189430-S2

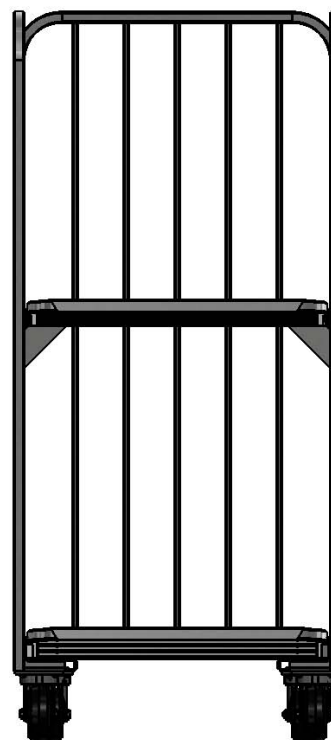
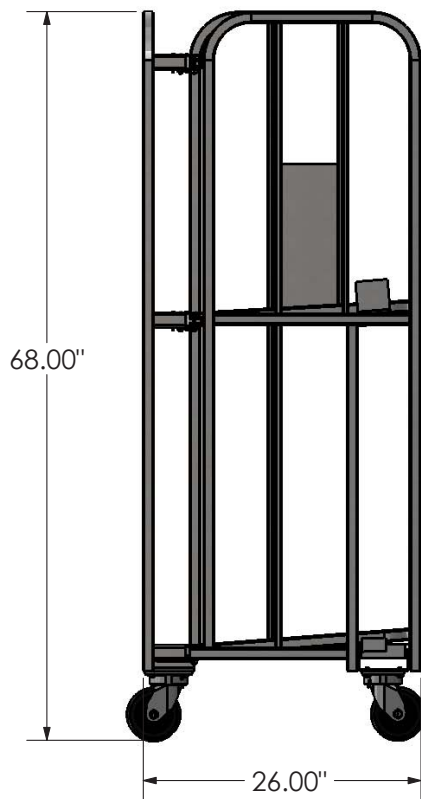
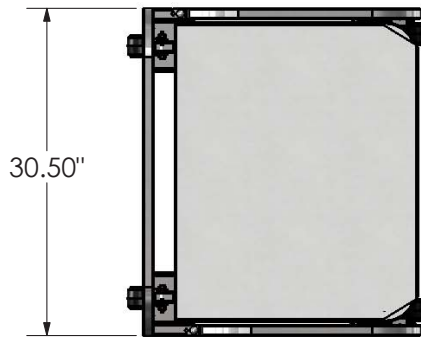

Order #	Model	W	L	H	Cart Capacity	Weight
48000457	DC-2629-2S-ZP, DAIRY CART, 2 SHELF	25 7/8"	30 1/2"	67 7/8"	1000 lbs.	135 lbs.

Can't find exactly what you need? Give us a call and we'll help you with the perfect solution!



NATIONAL CART CO

PH: 800-455-3802

www.nationalcart.com

Revision Date: Mar. 2013