

Chalkboard Display

A chalkboard display is a great addition to your stores marketing and sales effort. The display is the perfect size to advertise store specials, new products, and other messages you want to tell the general public. The rust free finish is perfect for inside use or outside that will not corrode.



FEATURES:

- Heavy duty steel construction that looks great and will not corrode if displayed outside
- Galvanized finish
- Fully assembled and ready to use
- Chalkboard display is mobile which makes it great for inside and outside use
- Wheels come with locking brakes to keep the display from moving

OPTIONS:

- Customize your chalkboard stand with your stores name or logo on the top header (inquire with your customer service representative)

REPLACEMENT PARTS:

- (4) heavy duty rubber swivel casters with brakes. Order #B000144





Freight Class: 175
 NMFC Code: 189430-S2

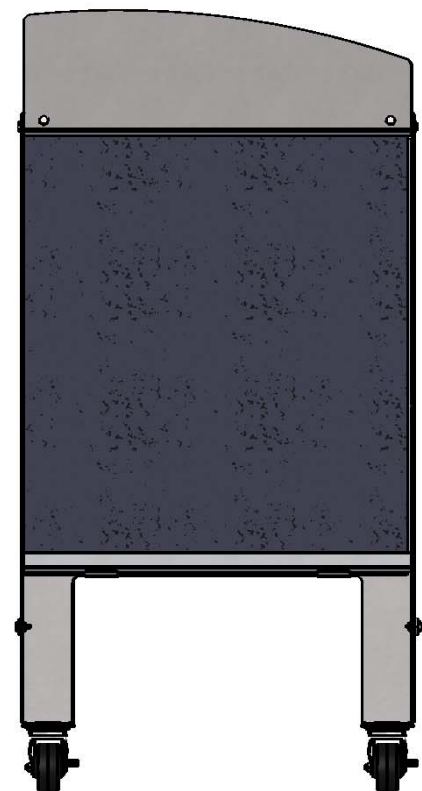
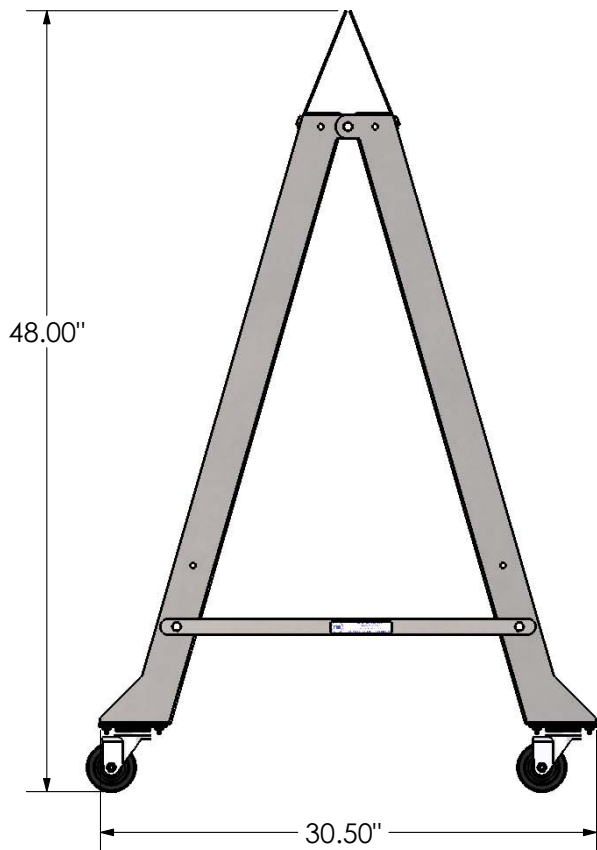
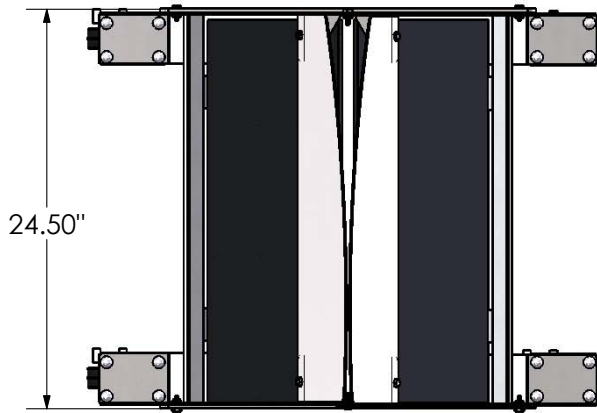

Order #	Model	W	L	H	Weight
8000371	SCS-2449 SIDEWALK CHALKBOARD DISPLY	30 1/2"	24 1/2"	48"	83 lbs.

Can't find exactly what you need? Give us a call and we'll help you with the perfect solution!

