

TOTE PICKING CART - WITH ERGONOMIC HANDLES

Increase your productivity with our quality purpose built e-commerce tote picking carts. This tote and cart combination provides a superior way to pick, organize, and deliver your e-commerce orders.

Custom Colors Available



FEATURES:

Heavy duty steel construction

Anti-slip tape on runners keeps empty totes in place

Ease of mobility with (4) swivel casters gives your associates maximum maneuverability in tight aisles

Corner bumpers

Ergonomic handle provides associates ease of handling

Top storage shelf features 0.75" lip to keep merchandise from falling

6 tote capacity

Includes bag holder and miscellaneous materials holder

Ships fully assembled and ready for immediate use

1000 lb. capacity

REPLACEMENT PARTS:

(2) 5" x 1.25" polyurethane swivel casters with brake. Replacement order #B000435

(2) 5" x 1.25" polyurethane rigid casters at the handle. Replacement order #B000325

OPTIONS:

Totes not included, please inquire within to order.

Picking Carts



Freight Class: 150
 NMFC Code: 188560-S4

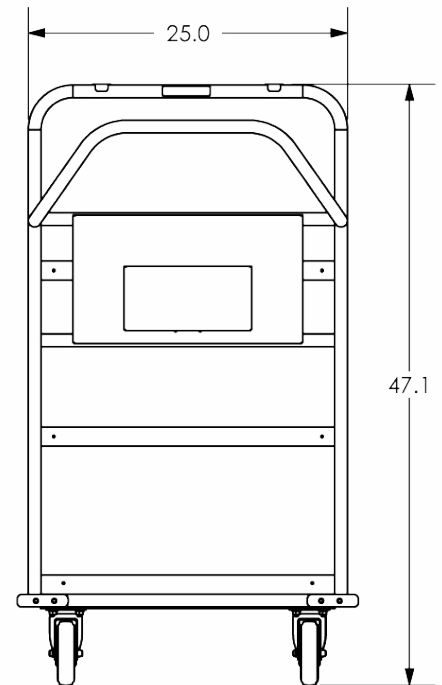
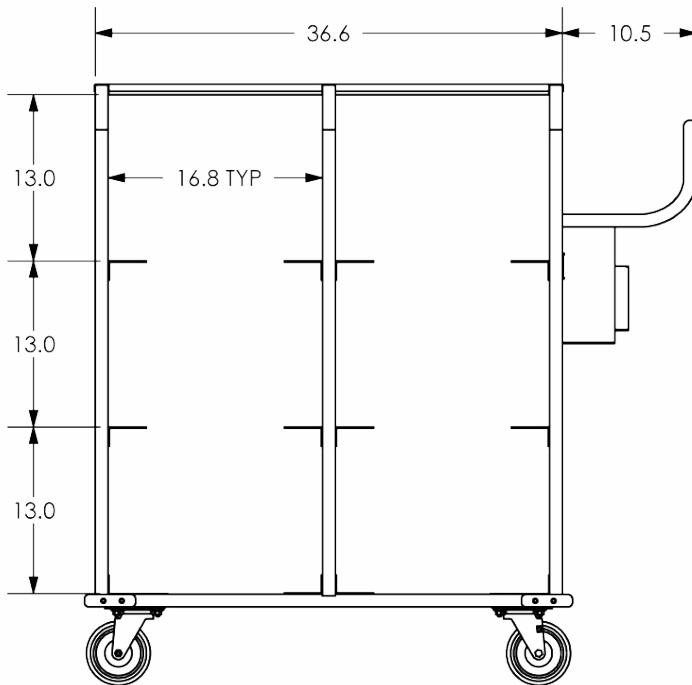
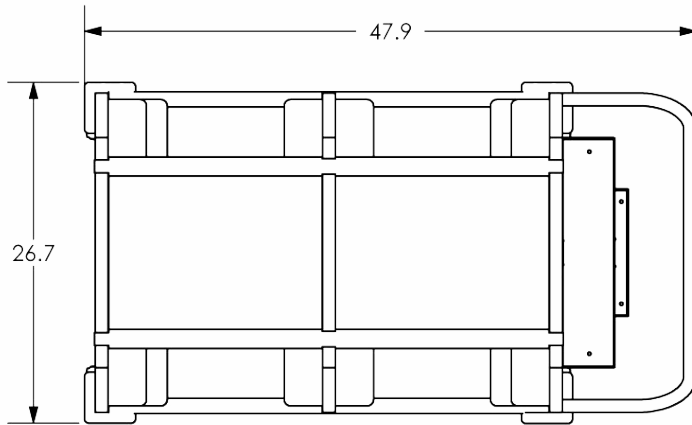

Order #	Model	W	L	H	Cart Capacity	Weight
8000518	TPC-2536-6	25"	47.9"	47.1"	1000 lbs.	100 lbs.

Can't find exactly what you need? Give us a call and we'll help you with the perfect solution!