

AISLE PICKING CART

Increase your productivity with our quality purpose built e-commerce tote picking carts. This pick to tote cart provides a superior way to pick, organize, and deliver your e-commerce orders.



FEATURES:

Light weight aluminum design

Cart designed to be pushed width-wise down an aisle for picking between gondolas

Value engineered with strength in right areas

Ease of mobility with (4) swivel casters gives your associates maximum maneuverability in tight aisles

Ergonomic full length handle provides associates ease of handling

Top storage shelf features 0.5" lip to keep merchandise from falling

9 tote capacity with maximum dims of 17.25 W x 22 L x 13.5 H

2" x 4" tote tag plates keep e-commerce orders organized

Ships fully assembled and ready for immediate use

300 lb. capacity

REPLACEMENT PARTS:

(4) 5" x 1.25" polyurethane swivel casters.
Replacement order #B000312

OPTIONS:

Totes not included. Inquire within to order.

Picking Carts



Freight Class: 150
NMFC Code: 188560-S4

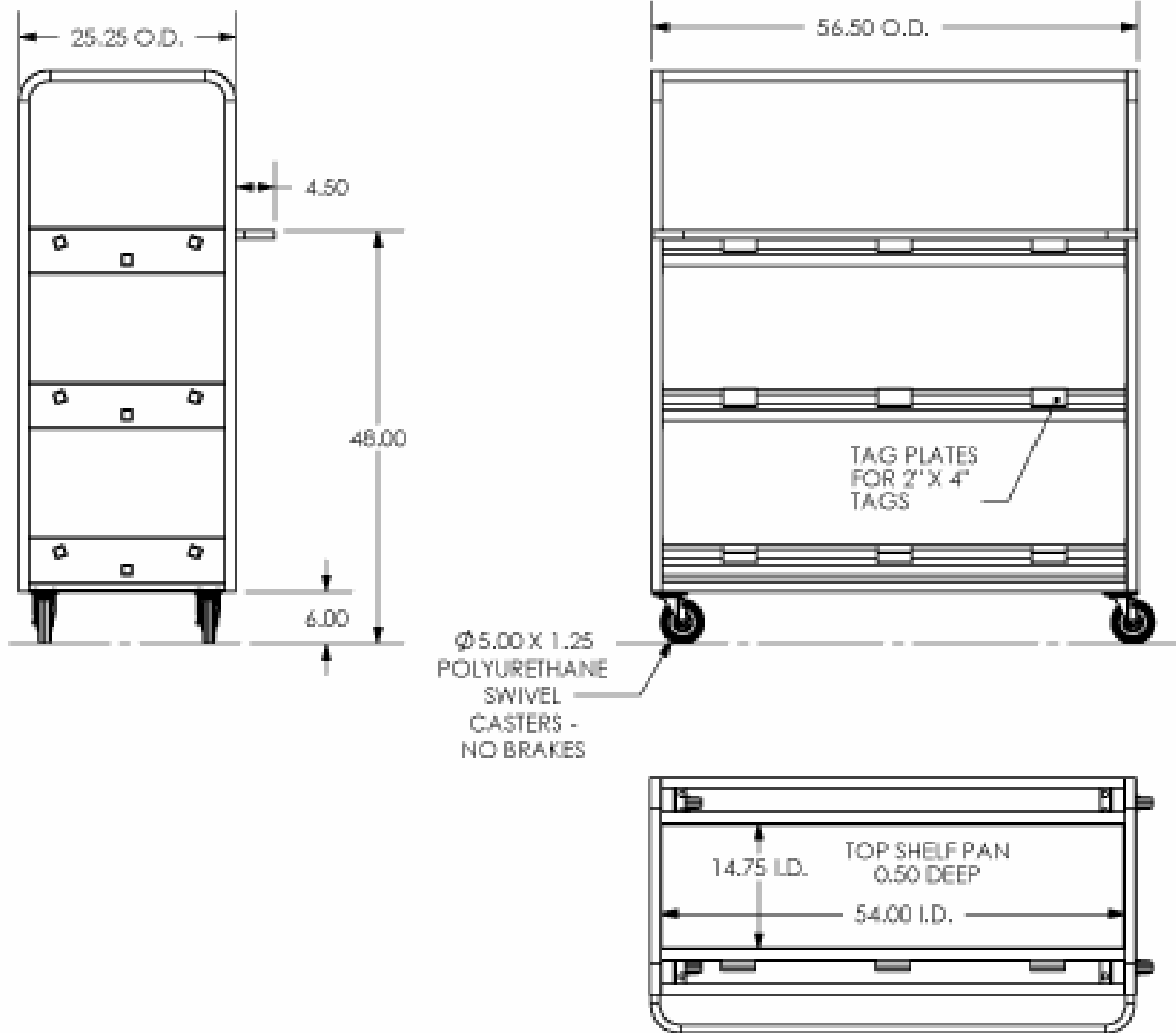

Order #	Description	W	L	H	Cart Capacity	Weight
8041328	AL-SPC-2556-3, PICKING CART, TUBE	25.25"	56.5"	66.6"	300 lbs.	200 lbs.

Can't find exactly what you need? Give us a call and we'll help you with the perfect solution!