

SPRING LOADED U-BOAT

Transform your u-boat into the perfect stocking cart with the spring leveling shelf. The heavy-duty spring allows for easy and ergonomic access to merchandise when stocking shelves.

The spring compresses to the perfect ergonomic work height, when loaded with the minimum weight of 400 lbs. The high end handles improve handling and help secure merchandise in place while in transit. The 16" width and six wheel design allow the cart to rotate within its own lengths and be easily maneuvered through busy aisles.



FEATURES:

All welded steel tube frame with heavy duty steel diamond deck

2 removable heavy gauge steel tube handles

Durable attractive blue powder coat finish

Traditional six wheel design, 2 center rigid and 4 corner swivel bolt on casters

Spring compresses completely when loaded with the minimum weight of 400 pounds

Spring leveled deck travels from 26 inches to 6.3 inches when compressed

OPTIONS:

Spring leveling shelf can be added to your existing 1660 u-boat with the purchase of two handles. Single handle part #1000199

*If adding spring leveling shelf to existing 1660 u-boat (part #5000101) New handles are required to prevent pinch points

Cardboard holder attachment #48010108 (attaches to a side handle)

Ergonomic spring leveling shelf #8010159

REPLACEMENT PARTS:

(2) 8" x 2" rigid polyurethane center wheels ensure easy rolling and longer life. Replacement order #B000024

(4) 4" x 1.25" corner swivel casters. Replacement order #B000027



1660 u-boat #5000197 shown with spring leveling shelf #8010159 and cardboard holder attachment #48010108



U-Boats
Freight Class: 70
NMFC Code: 188560-S2

Accessories
Freight Class: 70
NMFC Code: 188560-S9

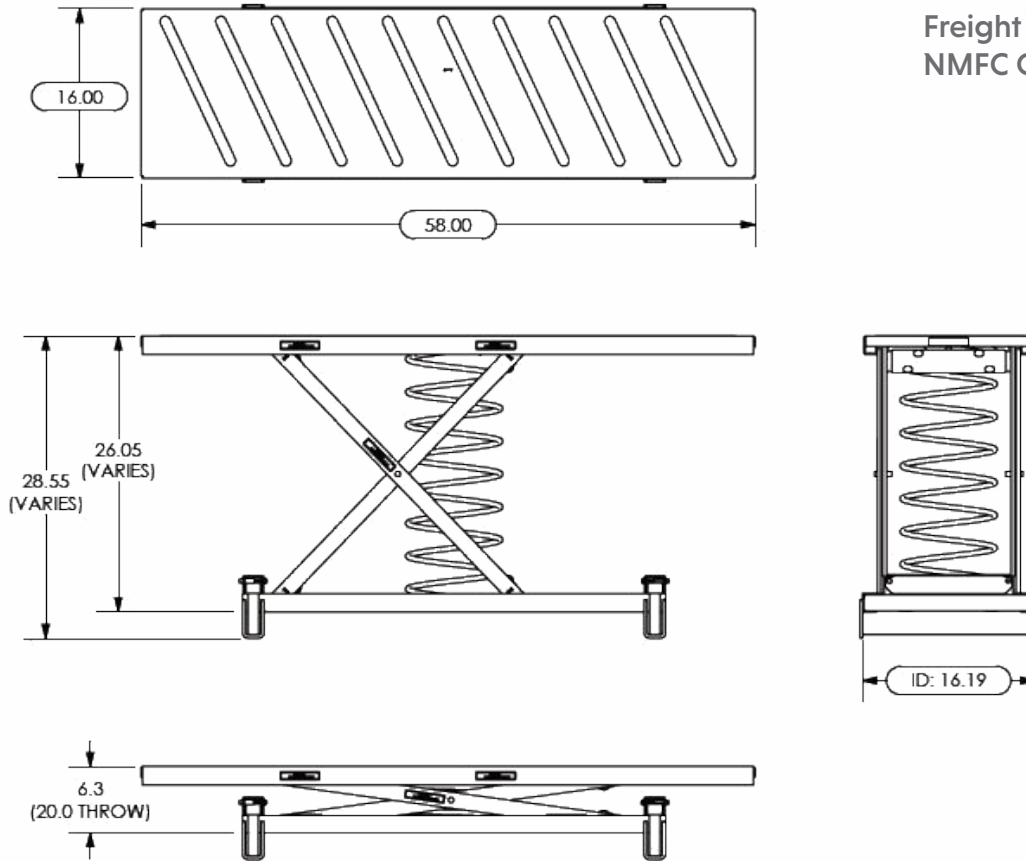

U-Boat

Order #	Model	W	L	H	Cart Capacity	Weight
5000197	1660-DD, TUBULAR HDL BOTH END UBOAT	16"	60"	61"	2200 lbs.	111 lbs.

U-Boat Spring Leveling Shelf

Order #	Model	W	L	H	Compatible U-Boat	Weight
8010159	SHELF, SPRING LOADED, UBOAT 1660	16"	58"	26"	5000197 or 5000101 with added handles	84 lbs.

*The spring leveling shelf can be added to an existing 1660 u-boat (part #5000101) with the purchase of two additional handles. Single handle part #1000199

Can't find exactly what you need? Give us a call and we'll help you with the perfect solution!