

TOTE PICKING CART - WITH STOWABLE DOLLY

Increase your productivity with our quality purpose built e-commerce tote picking carts. This tote and cart combination provides a superior way to pick, organize, and deliver your e-commerce orders.

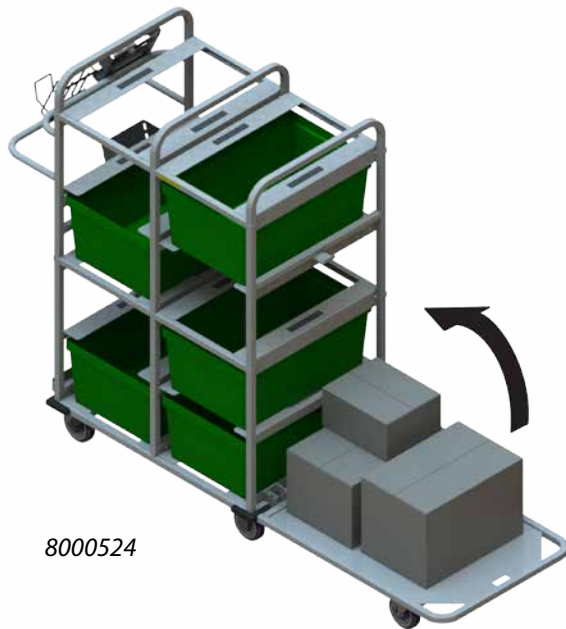

8000524



Adjustable tablet holder, miscellaneous materials holder, and printer holder



lower pocket and upper handle holds mops and brooms



Adjustable palm holder, miscellaneous materials holder, and printer holder



8000510

*Graphic sign frame
(Graphic Not Included)*

FEATURES:

Heavy duty steel construction

Anti-slip tape keeps empty totes in place

Ships fully assembled and ready for immediate use

Durable stone flex powder coat finish

1000 lb. capacity

8000524

10 tote capacity

Stowable drop down dolly for handling additional totes, boxes, or materials too large for totes

Slotted hinges allow dolly to drop into an "UP" position. The "L" bracket secures the dolly when it is folded up.

Includes adjustable tablet holder, miscellaneous materials holder, printer holder, and mop holder

(2) 5" x 1.25" polyurethane rigid casters on dolly, replacement order #B000325

8000510

8 tote capacity

Includes adjustable palm holder, miscellaneous materials holder, printer holder, and sign frame for graphics and advertising

REPLACEMENT PARTS:

(2) 5" x 1.25" polyurethane swivel casters with brakes at handle end of cart, replacement order #B000435

(2) 5" x 1.25" polyurethane swivel casters at the front of the cart, replacement order #B000312

OPTIONS:

24" x 16" Tote with stack and nest features in dark green. Part #5000190

Picking Carts



Freight Class: 150
 NMFC Code: 188560-S4

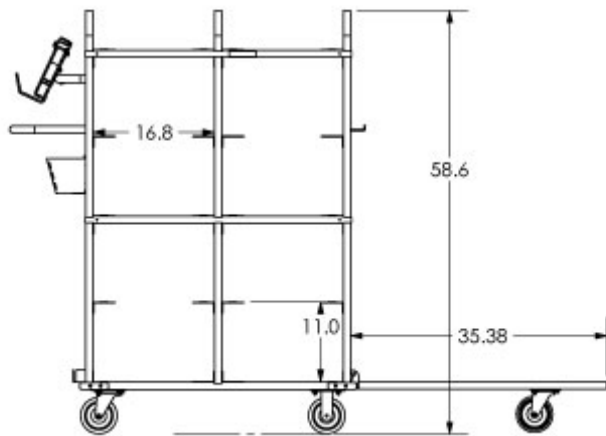
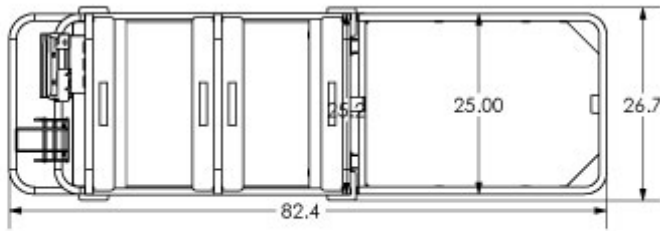

8000524

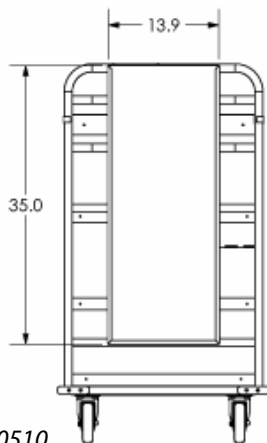

8000510

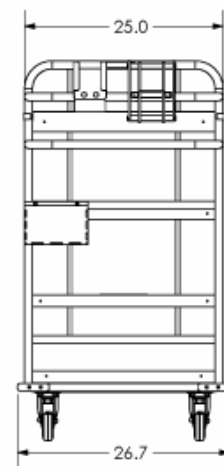
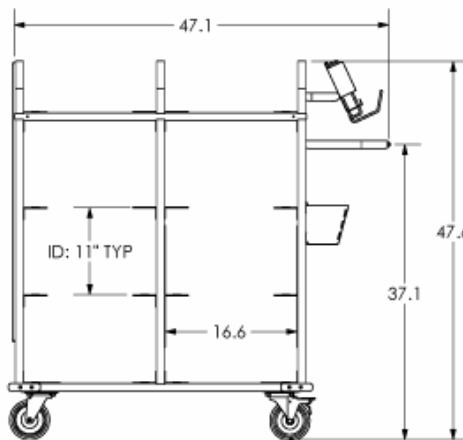

Order #	Model	W	L	H	Cart Capacity	Weight	# of Totes
8000524	WMPC-2638-S	26.7"	82.4"	58.6"	1000 lbs.	165 lbs.	10
8000510	WMHDC-2747-8-DL	26.7"	47.1"	47.6"	1000 lbs.	110 lbs.	8

Can't find exactly what you need? Give us a call and we'll help you with the perfect solution!