

Tote Picking Cart with Ergonomic Handles

Increase your productivity with our quality purpose built e-commerce tote picking carts. This tote and cart combination provides a superior way to pick, organize, and deliver your e-commerce orders.

FEATURES:

- Heavy duty steel construction
- Anti-slip tape on runners keeps empty totes in place
- Ease of mobility with (4) swivel casters gives your associates maximum maneuverability in tight aisles
- Corner bumpers
- Ergonomic handle provides associates ease of handling
- Top storage shelf features 0.75" lip to keep merchandise from falling
- 6 tote capacity
- Includes bag holder and miscellaneous materials holder
- Ships fully assembled and ready for immediate use
- 1000 lb. capacity

REPLACEMENT PARTS:

- (4) 5" x 1.25" polyurethane swivel casters, replacement order #B000312

OPTIONS:

- Totes not included, please inquire within for tote options





Freight Class: 150
 NMFC Code: 188560-S4

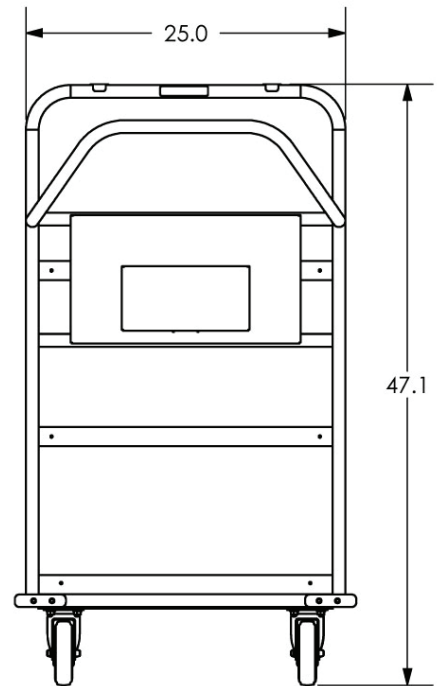
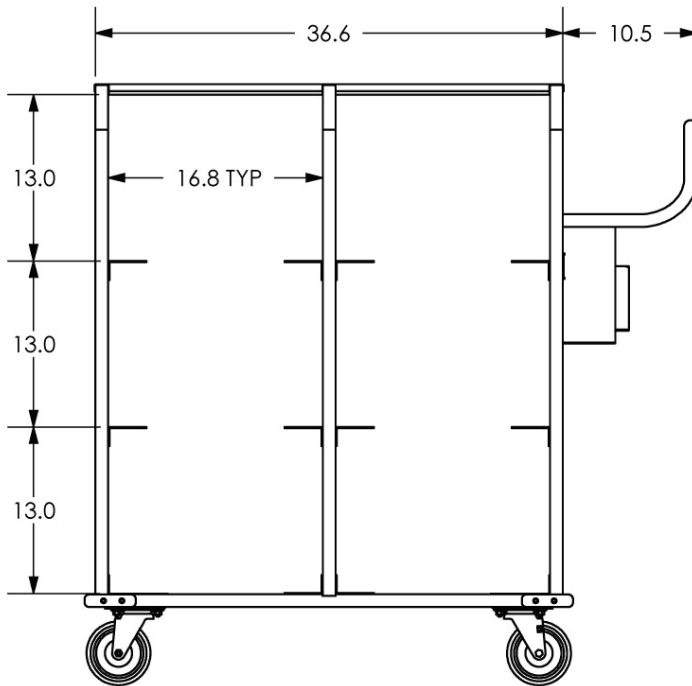
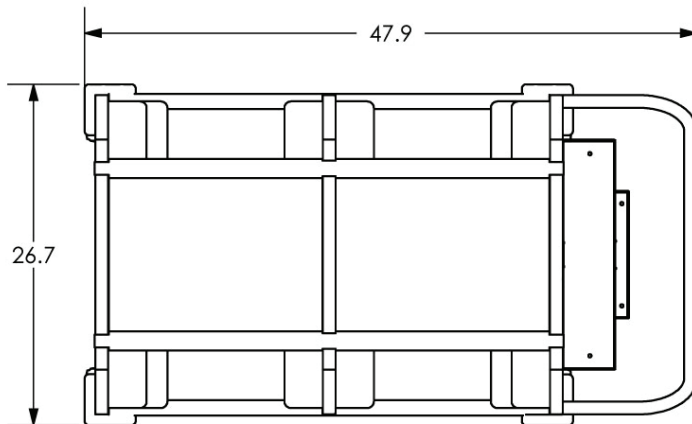

| Order # | Model | W | L | H | Cart Capacity | Weight |
|---------|------------|-----|-------|-------|---------------|----------|
| 8000518 | TPC-2536-6 | 25" | 47.9" | 47.1" | 1000 lbs. | 100 lbs. |

Can't find exactly what you need? Give us a call and we'll help you with the perfect solution!



NATIONAL CART CO

PH: 800-455-3802

www.nationalcart.com

Revision Date: Feb. 2015