

Lock and Load Dolly



The heavy-duty Lock and Load Dolly is your ultimate tote transporter and is suitable for all departments. The Load and Load dolly turns transporting heavy loads into a one person job and transports totes and boxes with ease. The pedal locking mechanism locks the dolly in place for safe loading and unloading of products.



FEATURES:

- Heavy-duty steel construction
- Lightweight aluminum handle
- Powder-coated safety yellow
- Red pedal activates brake system
- Green pedal deactivates brake system

Carts are stackable when not in-use to reduce storage space

OPTIONS:

- 23.5" L x 15.625" W Tote (custom sizes available)

REPLACEMENT PARTS:

- (2) 5 x 1.25" Rigid casters
- (2) 5" x 1.25" swivel casters with central locking brakes. Brake system total locks front two swivels

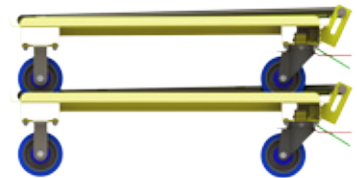

Dollies shown stacked



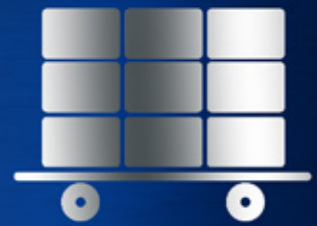

Material Handling

Freight Class: 100
 NMFC Code: 188560-S6

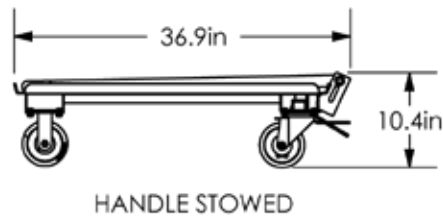
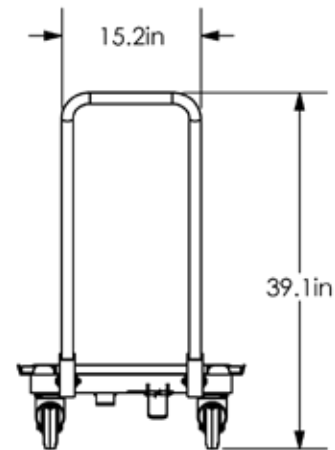
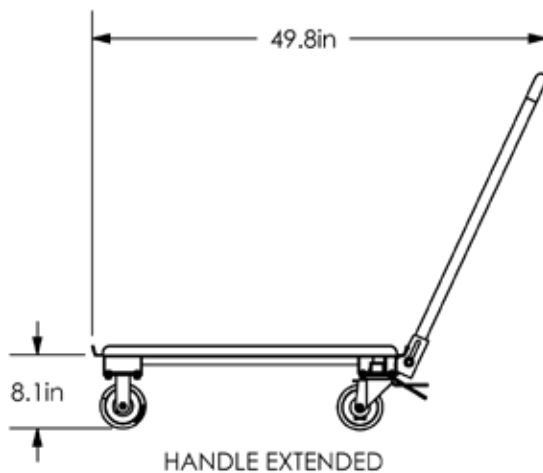
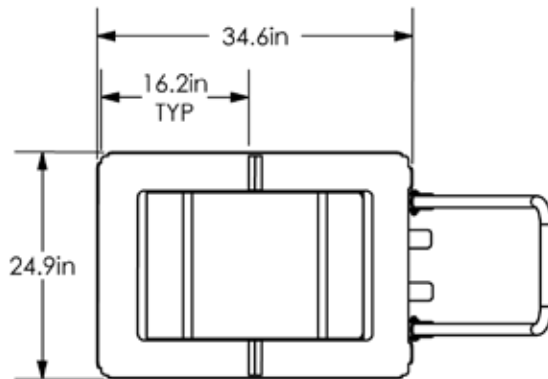

Order #	Model	W	L	H	Cart Capacity	Weight
8000564	TD-3224-2-TL, STEEL TOTE DOLLY- RH	24.9"	49.8"	39.1"	500 lbs.	97 lbs.

Can't find exactly what you need? Give us a call and we'll help you with the perfect solution!