

A Frame Basket Hanger

This mobile free standing floral merchandiser effectively displays hanging baskets. Merchandiser allows 360 degree viewing of the product while gaining maximum use of space. The design of this unit allows your product to become the center of attention.

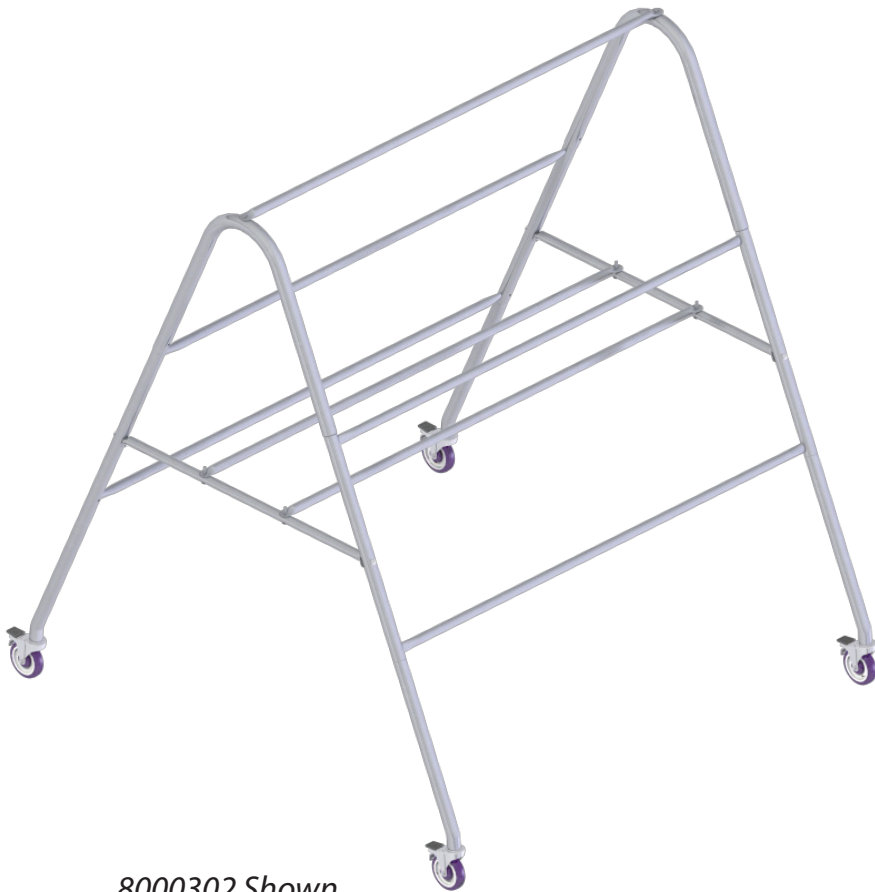

8000302 Shown

- FEATURES:**
- Sides of frame are made of 1.66" galvanized tubing. Cross members made with 1.16" galvanized tubing.
 - Ships (KD) knock down for freight savings
 - Assembles easily with minimal tools
 - Unit comes standard with 4 locking casters

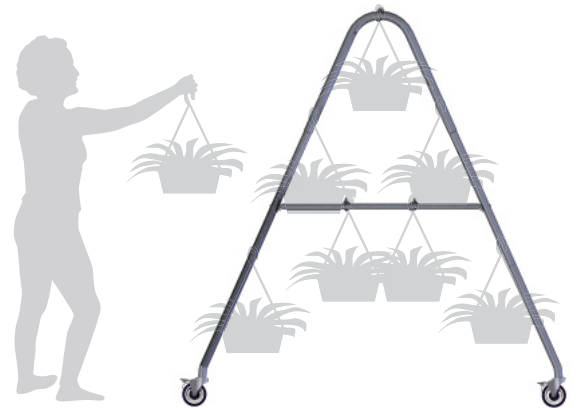



Merchandising

Freight Class: 85
 NMFC Code: 163980

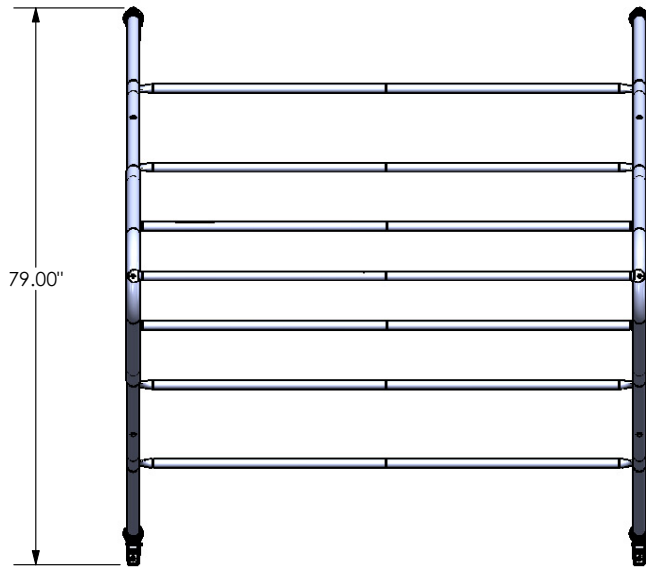

8000302

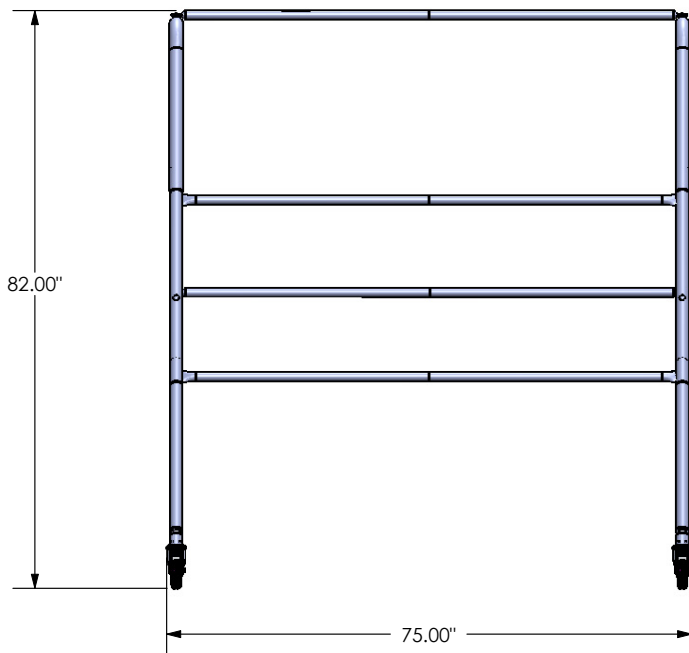

Order #	Model	W	L	H	Weight
8000302	A FRAME BASKET HANGER	75"	79"	82"	148 lbs.

Can't find exactly what you need? Give us a call and we'll help you with the perfect solution!



NATIONAL CART CO

PH: 800-455-3802

www.nationalcart.com

Revision Date: Mar. 2013